

VORTAC CMI 110.0 Chan 37	APP CRS 025°	Rwy Idg TDZE Apt Elev N/A N/A 735
--	------------------------	---

VOR-A
FRASCA FIELD (C16)

V Circling NA to Rwys 18 and 36. Use Champaign altimeter setting; when not received, use Decatur altimeter setting and increase all MDAs 80 feet and Cats A/B/D visibilities ¼ SM, Cat C visibility ½ SM; increase FANUK DME fix minimums Cats C/D visibility ½ SM.

NA MISSED APPROACH: Climb to 2000 then climbing right turn to 2500 on CMI VORTAC R-062 to OCTOE INT and hold.

CHAMPAIGN APP CON ★ 121.35 285.65	UNICOM 122.8 (CTAF)
---	-------------------------------

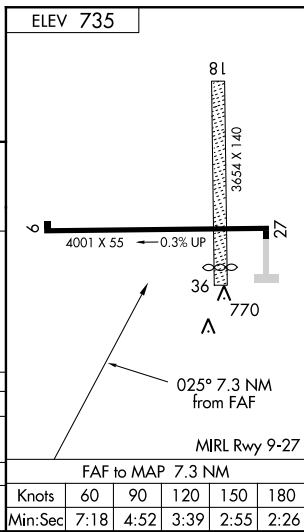
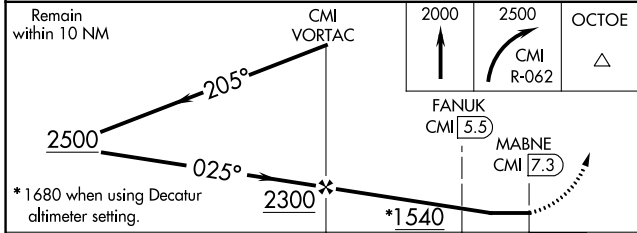
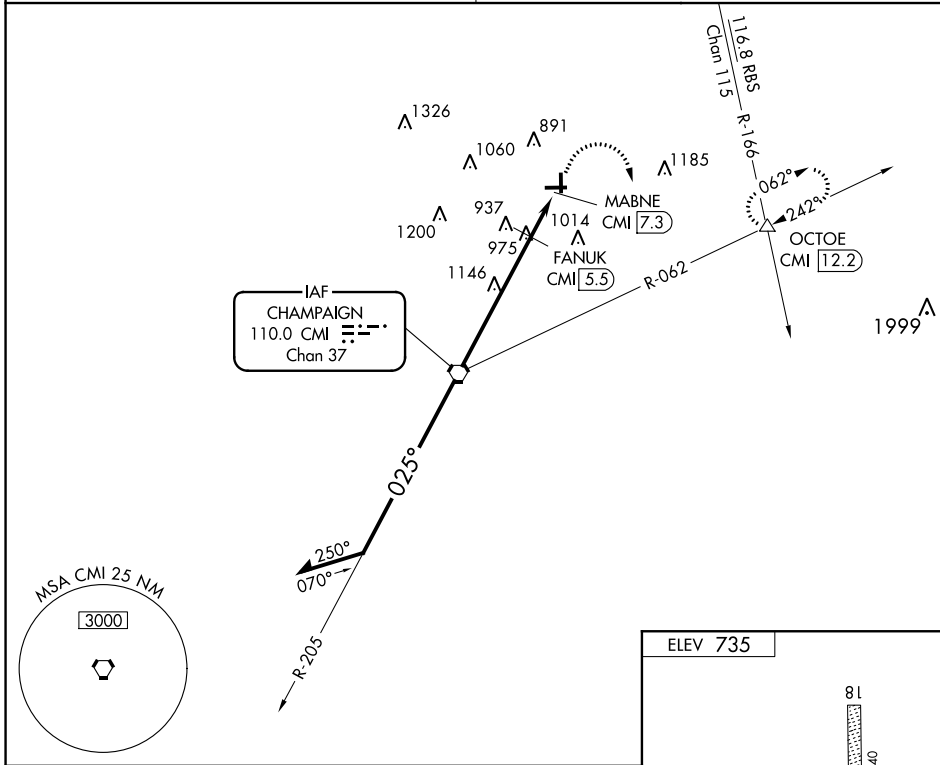

CATEGORY	A	B	C	D
C CIRCLING	1540-1 805 (900-1)	1540-1¼ 805 (900-1¼)	1540-2¼ 805 (900-2¼)	1560-2¾ 825 (900-2¾)
FANUK DME FIX MINIMUMS				
C CIRCLING	1300-1	565 (600-1)	1420-2 685 (700-2)	1560-2¾ 825 (900-2¾)

FAF to MAP 7.3 NM					
Knots	60	90	120	150	180
Min:Sec	7:18	4:52	3:39	2:55	2:26